

| PARTS LIST | | | |
|------------|------------------------|-----------------|------|
| NO. | TITLE | MATERIAL | QTY. |
| 1 | Oxley Bike Rack GA | | 1 |
| 2 | Threaded Rod M10x150mm | Stainless Steel | 4 |
| 3 | Washer-M10-Regular | Stainless Steel | 8 |
| 4 | Hex Nut-M10 | Stainless Steel | 12 |

| ISSUE | DESCRIPTION | DRAWN | DATE |
|-------|-----------------|-------|------------|
| A | Initial Release | TW | 06/06/2018 |

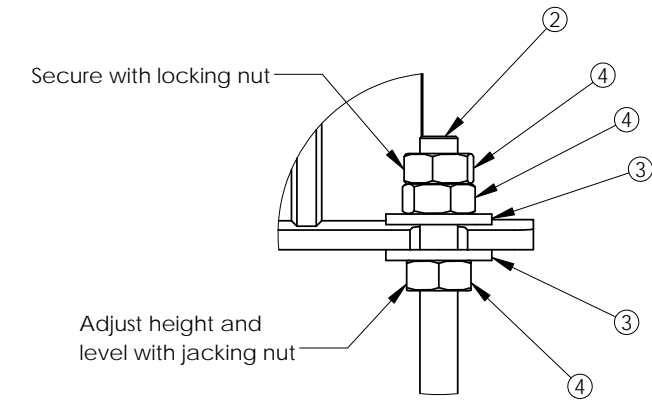

DETAIL A
SCALE 1 : 2

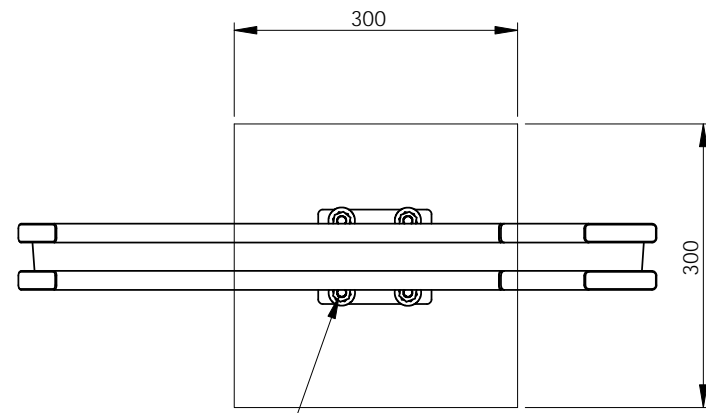
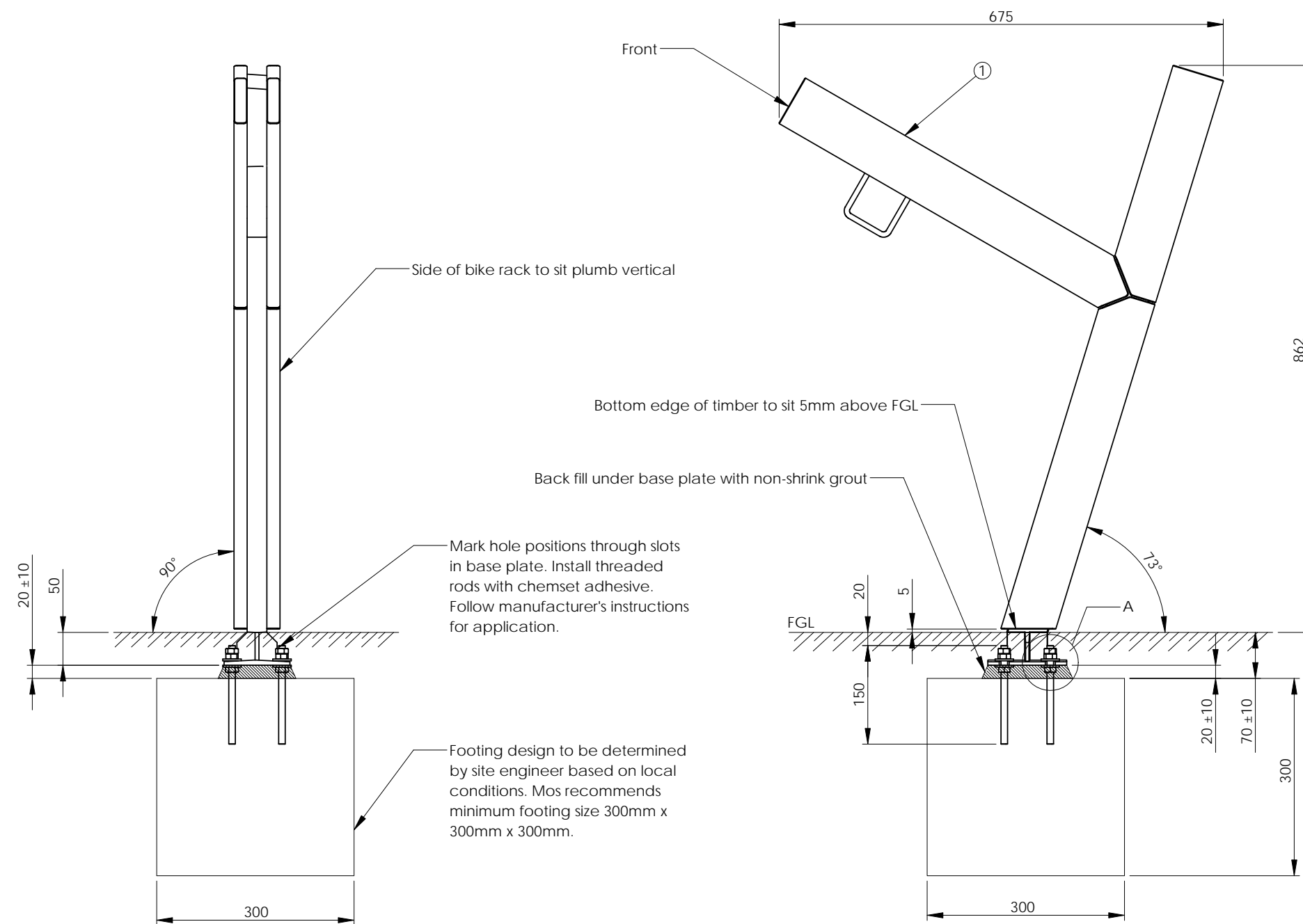

- GENERAL NOTES:
- All dimensions in millimetres unless otherwise shown.
 - Linear Tolerances:
 x ± 1.0
 x.x ± 0.5
 x.xx ± 0.1
 Angular Tolerances:
 ±0.5°
 - No deviation from drawing will be accepted without prior written approval.
 - Do not scale from drawings. Use dimensions provided if this is insufficient or ambiguous contact Mos for clarification.

| | | | | |
|-----------------------------|---------------------------|---------------------|---------------|--------------|
| Title: Installation | | | | |
| Product: Oxley Bike Rack | | | | |
| Dwg No: 1023-851 | Date Drawn: 06/06/2018 | Sheet No: 1 of 1 | Scale: 1:8 | Sheet: A3 |

